

**INSTALLATION INSTRUCTIONS**

**FOR 918B / IT 918B CAT LOADER**



**PHONE: (519)485-5961 OR 1-800-267-2665  
FAX (519)485-3745 OR 1-888-267-3745**

## EVAPORATOR INSTALLATIONS:

The evaporator assembly comes ready to drop into the space behind the heater coil. The heater coil is behind the drivers seat. Remove seat and cover panels to expose the heater core area. The heater coil is held into place by a metal flange on each end of the coil. Loosen off the flanges to allow the evaporator coil to slide down in behind the heater coil. To make room to slide the evaporator coil into place; temporarily disconnect the heater hoses obstructing the path of the evaporator coil. Once the evaporator coil is in position, centered with the heater coil, tighten up the flange bolts on each end of the coils. Replace the heater hoses. There are two pre-punched holes to accommodate the bulkhead fitting on the hoses coming from the evaporator coil. The upper hole is for the 1/2" hose and the lower is for the 5/16" hose. Remove the access plate from the back left side of the cab and drill two 1-1/8" holes, one on the lower left corner and one 2" higher for the freon hoses to pass through. Install the grommets supplied. Connect the 45 fitting on the 5/16" hose to the 5/16" bulkhead after running it through the bottom right grommet on the access plate. Connect the 45 fitting on the 1/2" hose to the 1/2" bulkhead after running it through the top left grommet on the access plate. Run the clutch wire with the 5/16" hose out of the cab. Route the hoses down and over between the cab and the compressor and condenser area.

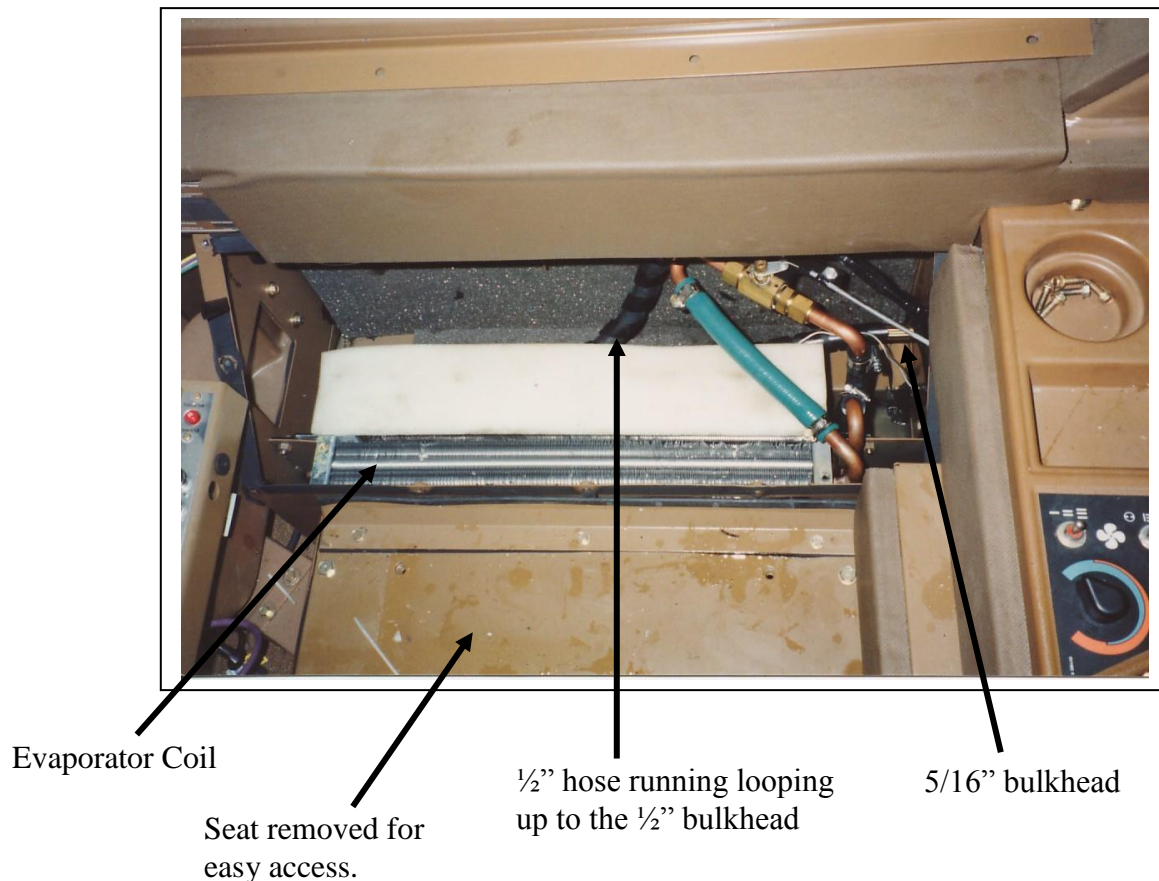



Evaporator flanges clamped in  
with heater lines.

Remove to install the evaporator coil  
and then replace.

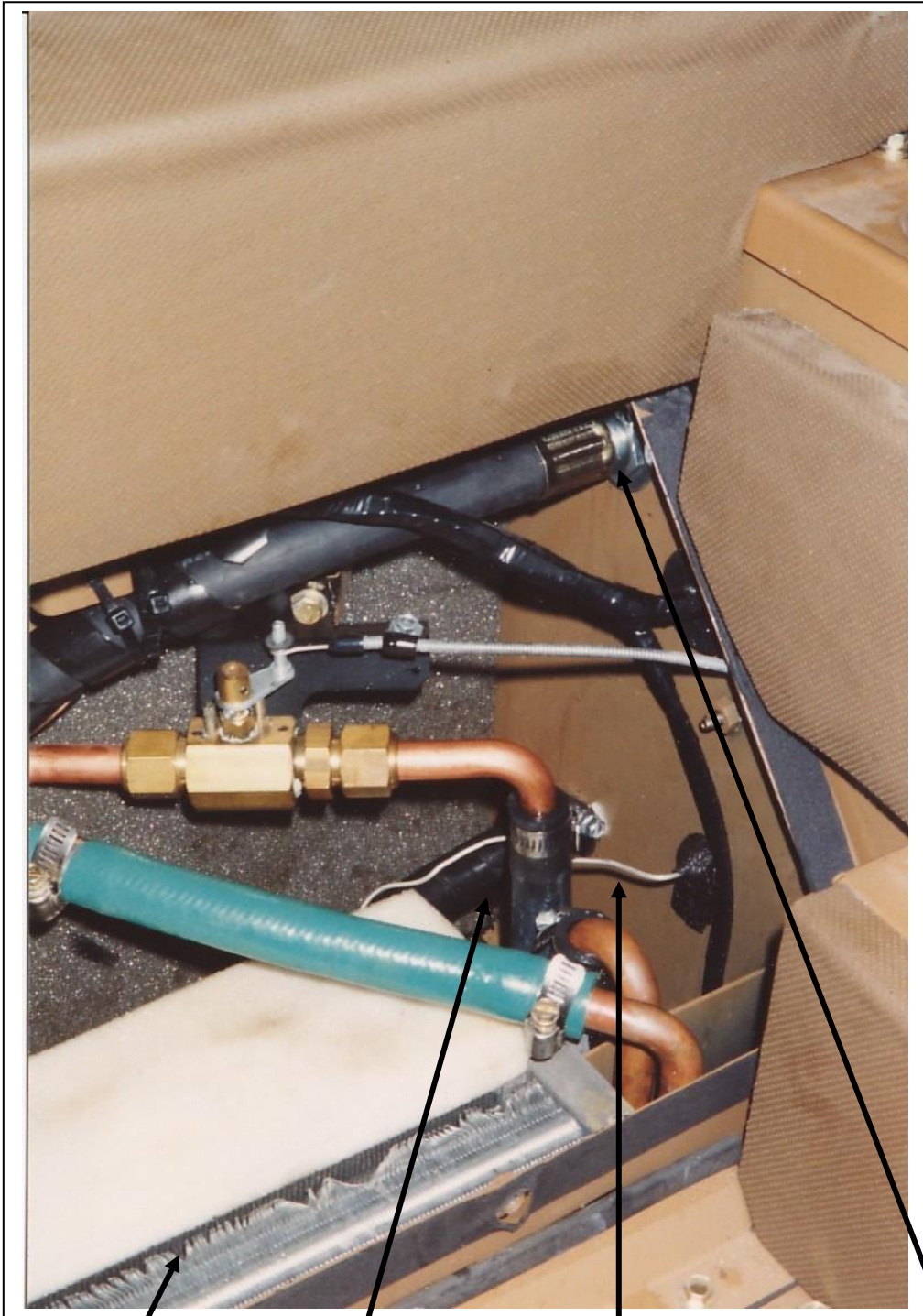

Evaporator coil

5/16" line to bulkhead fitting. (behind heater

Thermostat probe

1/2" bulkead fitting with fender washers.

## **THERMOSTAT INSTALLATION:**

The thermostat is mounted on the left-hand climate control panel. There is no pre-made factory hole, so a 7/16" hole must be drilled in the plastic bezel in the top front cover. Use the supplied temperature label to center the hole with appropriate clearance. Mount the thermostat in the hole and apply the label and knob. Connect a short wire from the a/c selector switch to the thermostat. Connect the black clutch wire to the other terminal of the thermostat switch and run out of the cab with the 5/16" freon hose. Continue the clutch wire through the pressure switch and then up to the clutch wire on the compressor. Route the thermostat probe through into the evaporator coil area and inset the end into the coil. Insert the thermostat probe 8" from the expansion valve end, about 1/2 way down the height of the coil.



Thermostat location. Hole must be drilled.

## **DRYER INSTALLATION:**

The dryer is mounted on the left-hand main beam about half way down towards the compressor. The dryer is attached to a straight bracket bolted to the main beam. Secure the dryer to the bracket using the two #48 hose clamps provided. The 5/16 hose from the evaporator connect to the output side of the dryer and the 5/16" hose from the condenser attached to the inlet side of the dryer.



General location of the receiver drier on the left side of the engine. The mount bracket will be bolted to the main beam.

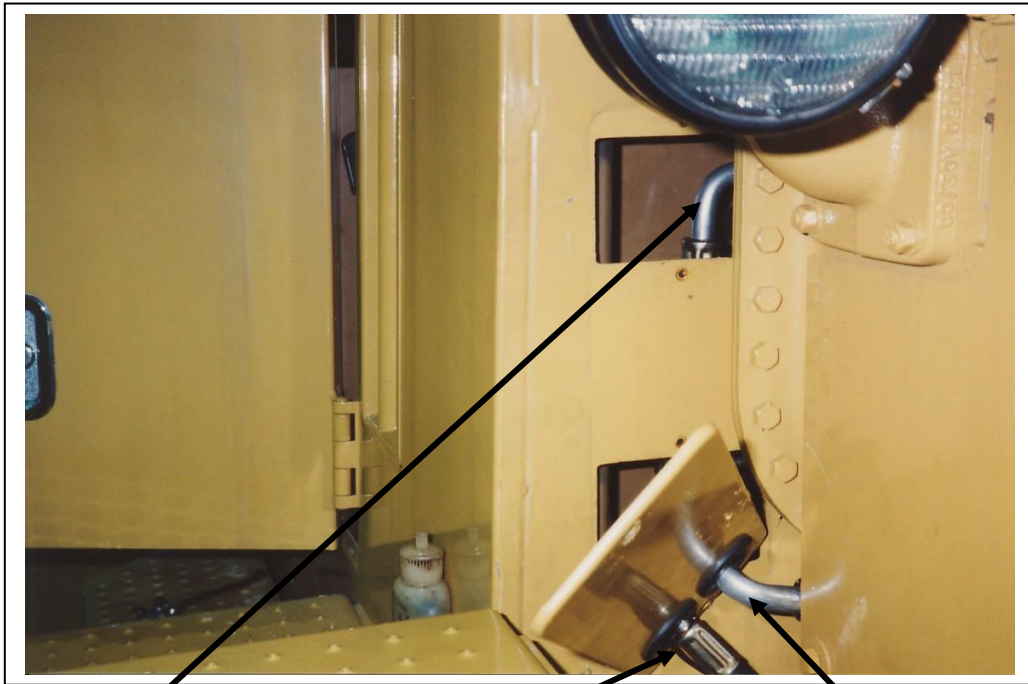

1/2" 90° fitting attaching to the 1/2" bulkhead fitting.

5/16" hose entering cab area through the installed grommet.

1/2" hose entering cab area through the installed grommet.

NOTE: The 90° splices shown in these two pictures are no longer used.



Hose and clutch wire entering the cab.

## **COMPRESSOR INSTALLATION:**

Bolt the compressor mount onto the engine using the five ½” threaded holes on the upper right side of the engine. Set the compressor in place on the tightener ears of the mount and loosely bolt down with the 3/8” x 1 ½” bolts provided.

Install the belt, tension the belt and tighten the compressor bolts to hold it in place.

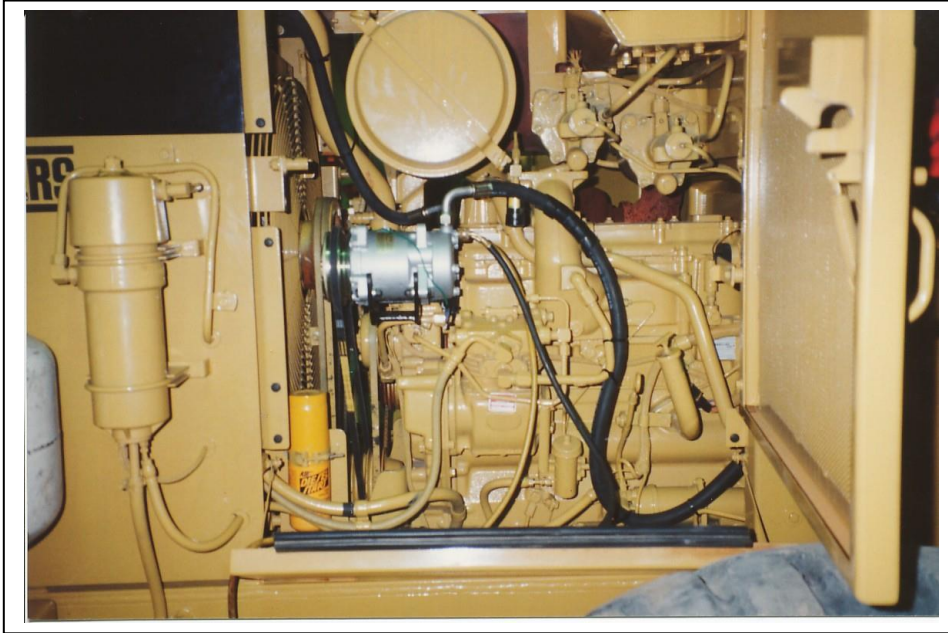

Compressor and mount in place

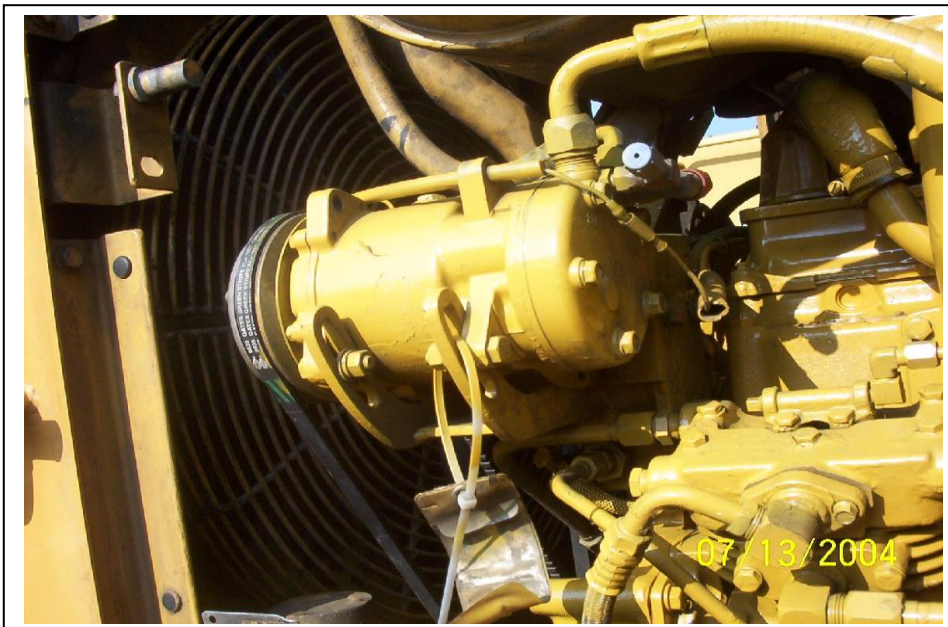

NOTE: Hose connections and compressor tail plate have changed from these two pictures.

## **CONDENSER INSTALLATION:**

The condenser coil mounts directly to the fan shroud using 2 “Z” mounting brackets and two spin lock hold down bars. The mounting brackets are bolted to the condenser coil frame on the top end and have a 3/8 square threaded bar on the bottom. Place the condenser coil in position on the screen, then turn the 3/8 square bar parallel with the fan shroud screening and slipped through. When the bars are through the fan shroud, use a screw driver or other probe to turn the 3/8” threaded bars 90-degrees to the fan shroud screening and tighten them down. Mark, drill and tap the top two mount brackets for 3/8” bolts and bolt into place on the fan shroud. Connect the 5/16” hose to the small fitting on the bottom left of the condenser. Connect the 13/32” hose to the larger fitting on the top left of the condenser. Use the tie wraps provided to secure the hoses to the fan shroud.

SLIP THE SPINLOCK  
BETWEEN THE FAN  
SCREEN BARS

FAN SCREEN  
SPINLOCK

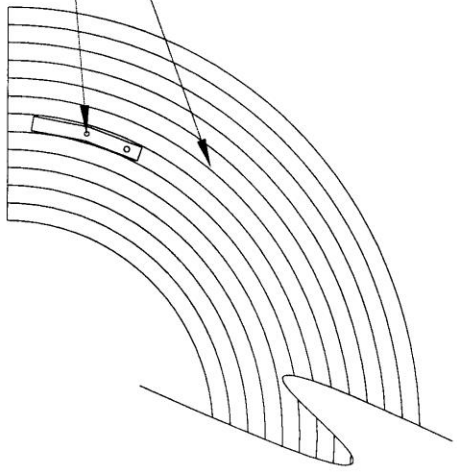

AND ROTATE 90 DEG.  
AND TIGHTEN DOWN

CONDENSER  
FENDER WASHERS

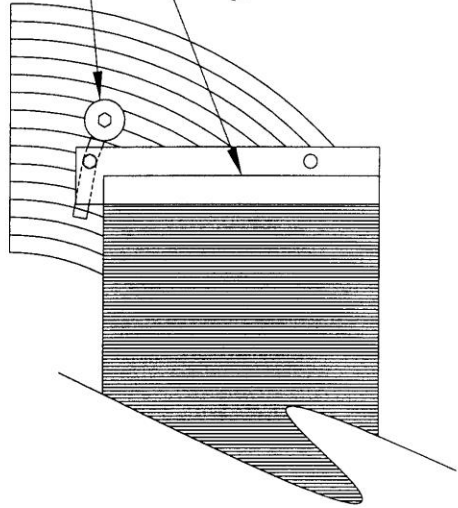

DRAWING TITLE:  
**SPINLOCK INFO.**

DRAWN BY:	J.S.
APPROVED BY:	J.L.
MODIFIED ON:	MAR. 15, 2002
REV:	0
UNITS:	S.A.E.

### **INSTALLATION HINTS:**

- 1) When system is completely installed, pressurize, and test for leaks before re-installing any cover plates over system components.
- 2) Use refrigerant oil on all flares and threads when connecting fittings.
- 3) Take special care not to introduce any dirt into system. Even small amounts of internal dirt may jam system components.
- 4) Clutch will not work unless there is pressure in the system.

## Refrigerant Flow Pattern in a Standard Air Conditioning System

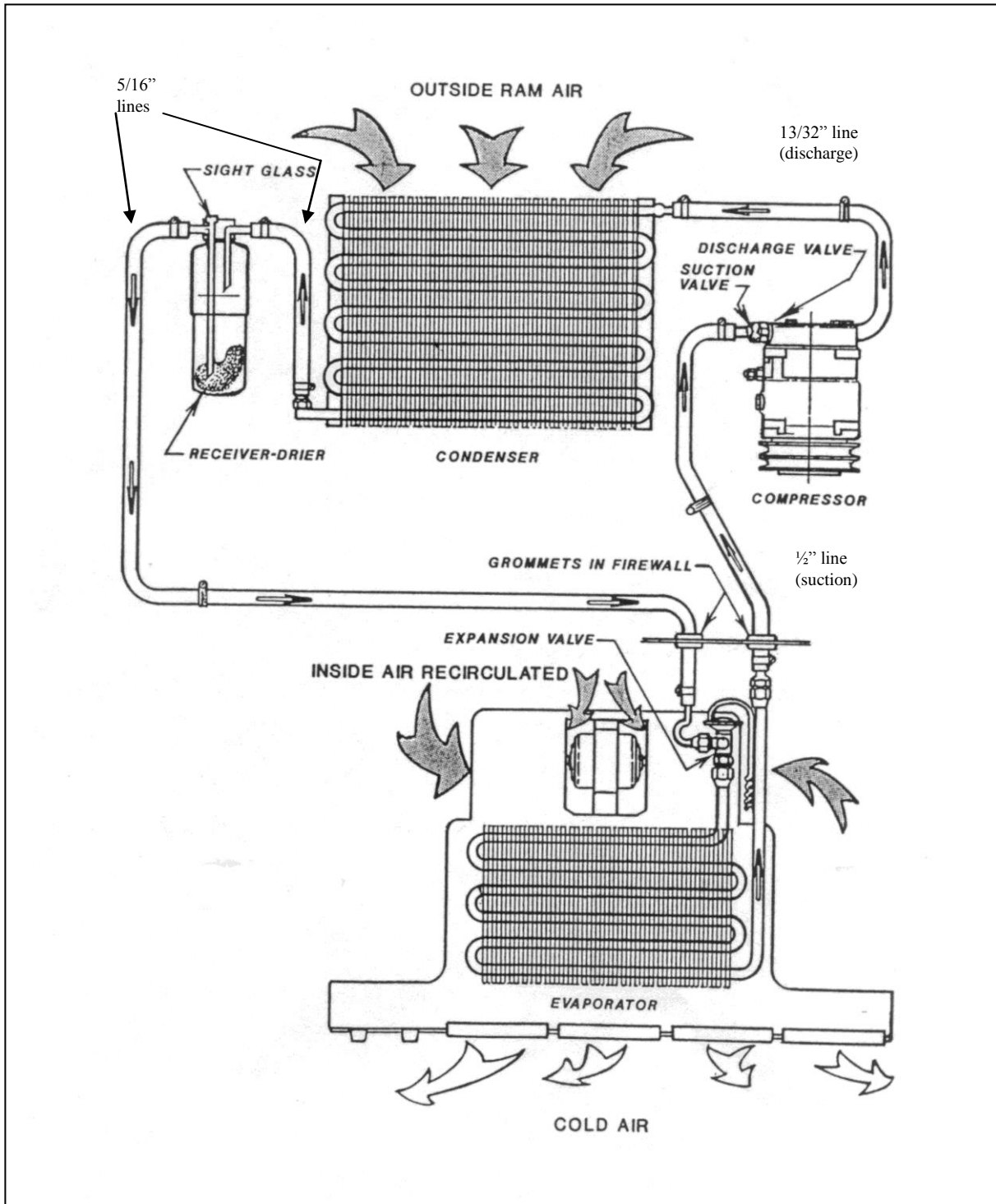

## Thermostat Setting Procedures

- 1) Thermostat types
  - a) preset
  - b) adjustable
    - a) A preset thermostat is adjusted to its specific cut in and cut out temperatures when manufactured and does not have a rotary adjustment for the operator.
    - b) An adjustable or rotary thermostat has been manufactured to a predetermined cut in and cut out temperatures, but it is also operator adjustable to achieve the desired comfort level.

Both types of thermostats can have their factory settings adjusted by turning the setting screws on the body of the thermostat. One body type has the setting screws mounted externally and labeled for direction of rotation. The other body type requires the removal of the plastic end plate to expose the set screw.

- 2) Thermostat probe location: The location of the thermostat probe in an evaporator coil can be very important to achieve the maximum cooling potential of the coil while also preventing coil freeze-up. There is no set location for the thermostat probe to be put that will be optimum for all systems, but several rules of thumb may be followed:
  - a) Insert the probe in the coldest area of the evaporator coil.
  - b) Insert the probe from the top of the coil down, if possible.
  - c) Make sure that at least the last 3" of the thermostat probe are in the coil.

To find the most likely area where the coil is the coldest, consider these factors:

- 1) Direction of air flow through the coil.
  - 2) The coil area likely to have the lowest air flow.
  - 3) The inlet locations of the refrigerant into the coil.
  - 4) The inlet of the hotter outside air into the coil area.
- 
- 1) Usually the coldest side of the evaporator coil will be the air outlet side. Often the thermostat probe can be inserted between the last and second last row of tubes.
  - 2) The lower air flow area of the evaporator coil in most systems tends to be near either end of the coil. These areas will be colder
  - 3) The area of the coil that the refrigerant inlet tube(s) occupy should be the coldest part of the coil.
  - 4) If the system is equipped with an outside air intake, where and how that air is brought into the evaporator area can have a large effect on the coil temperature. If all the outside air is piped into the evaporator in one area, that area will be considerably warmer in hot weather.

By looking at all these different factors, the area of an evaporator coil most likely to be the coldest can be determined.

Once the probe is inserted, the A/C system needs to be tested. Run the system to ensure that the thermostat is cycling the compressor off at the appropriate temperature. A core temperature ranging between 25° and 30° F should cause the thermostat to cycle off. The air temperature at the vent outlet closest to the evaporator coil should be between 38° F and 45° F when the compressor cycles off.

If the thermostat doesn't cycle off after a reasonable cool down period, and the air outlet temperature has dropped below 40° F, the cut in and cut out settings should be adjusted until the compressor is cycling on and off regularly. Let the system run for a decent time period (at least 15 min) and then check the evaporator coil for any signs of freezing.

## Aeroquip E-Z Clip Assembly Instructions

Step 1. Cut the hose to proper length with an appropriate cutting tool. Aeroquip's hand held hose cutter has been specially designed for cutting all non-wire reinforced hose, such as GH-134 Multi-Refrigerant hose. Be sure the cut is made square to the hose length.

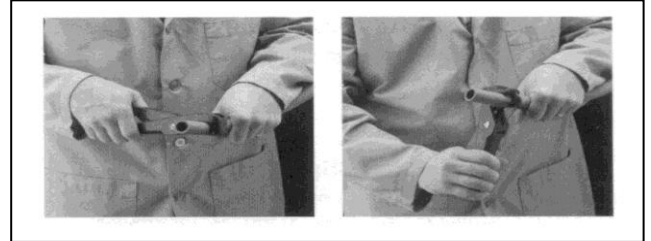

Step 2. Install two proper-sized clips onto the cut end of the hose. Orientation of the clips does not affect the performance of the connection. However, for ease of assembly, both clips should have the same orientation. NOTE: Failure to slide the clips over the hose at this time will require the clips to be stretched over the hose or fitting later. This may permanently damage the clip.

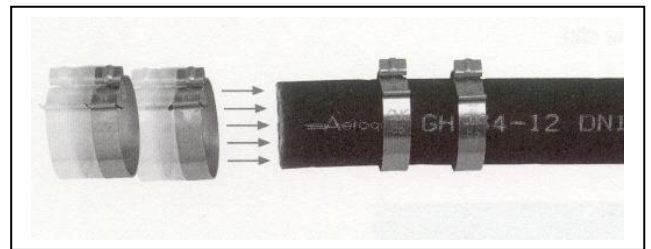

Step 3. Lubricate the nipple with a generous amount of the refrigeration or A/C system's compressor lubricating oil. This MUST be done to lower the force of nipple insertion.

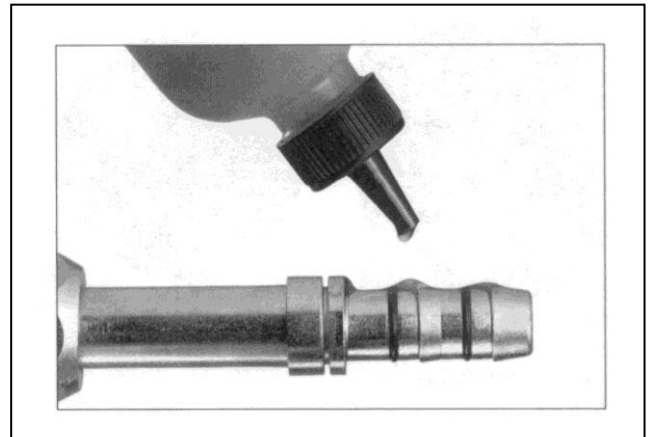

Step 4. Insert the nipple into the hose. To ensure that the nipple is fully inserted, check the gap between the cut end of the hose and the shoulder on the nipple. Care should be taken to avoid kinking or other damage to the hose during nipple insertion. NOTE: Be sure to wipe excess oil from the nipple and hose.



Step 5. Snap the cage into the groove on the nipple. The arms should extend over the hose length. When the cage has been correctly installed in the cage groove, the cage will be able to rotate in the groove. This step **MUST** be performed to ensure:

1. The clips will be located over the O-rings on the nipple.
2. The connection will be compatible with the connection's pressure rating.

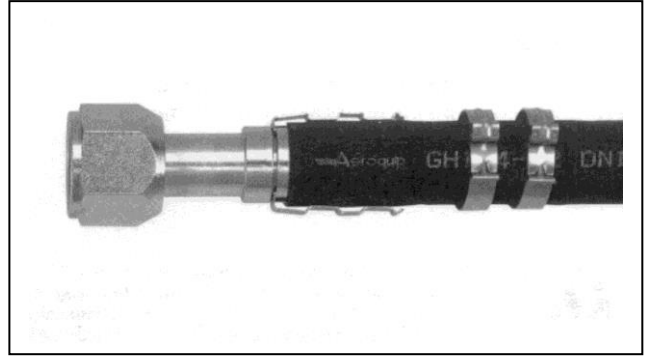

Step 6. Slide the clips over the cage arms and into the channels on each arm.

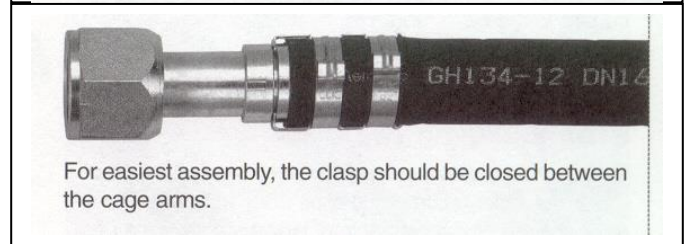
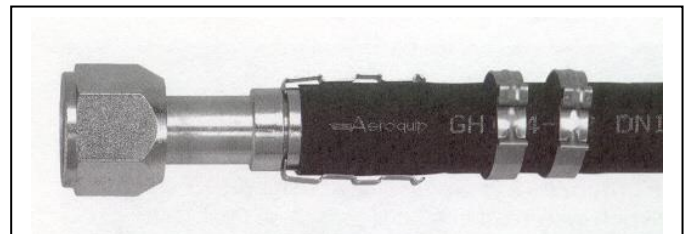

Step 7. Use the pliers to close the clips. The pliers should be positioned squarely on the clip connection points and should remain square during the closing of the clip.

**NOTICE:** E-Z Clip components should not be reused.

